

TD-15 TYPICAL POST WRAP DETAIL FIELD FORMED

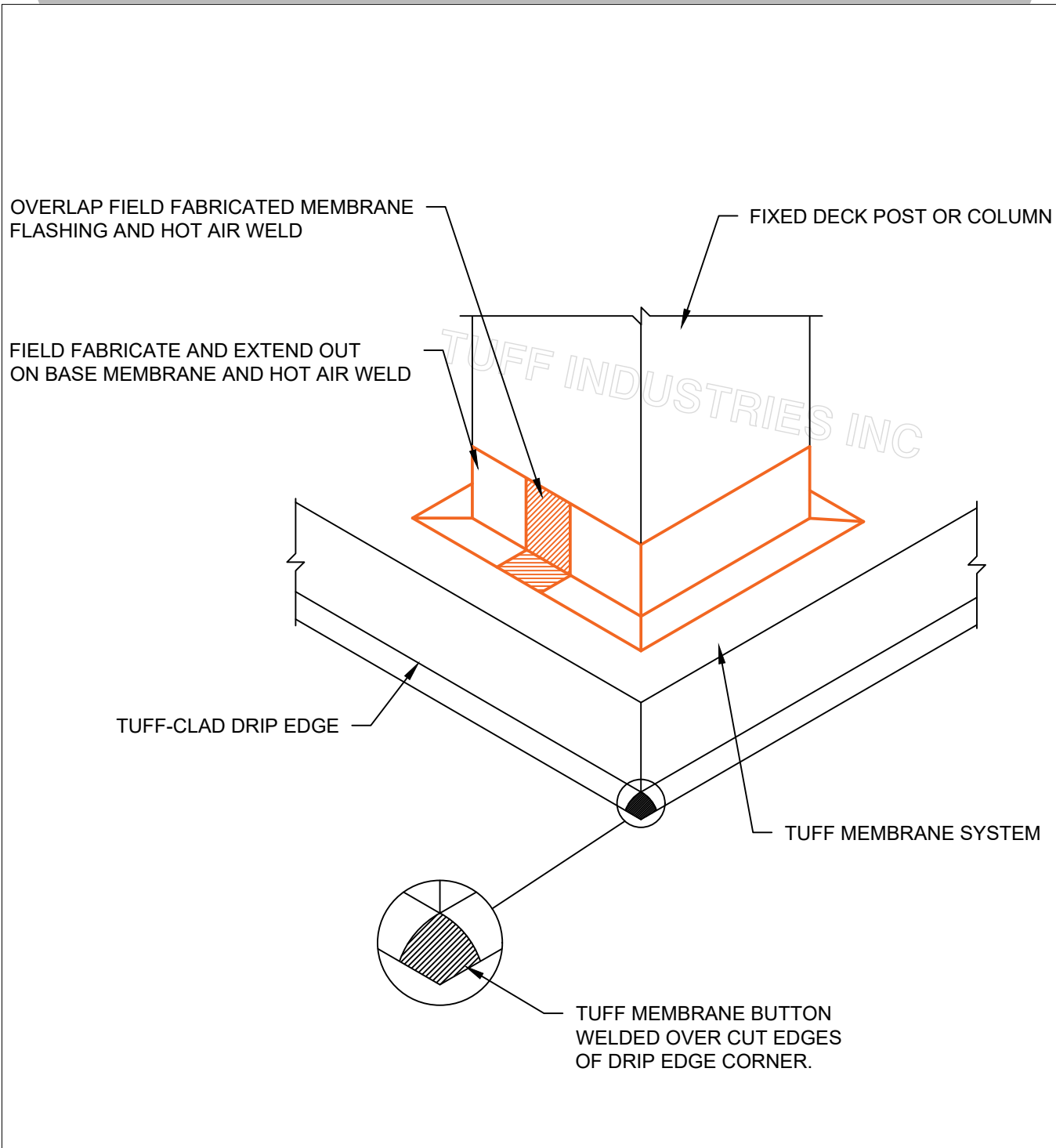

TD-15 TYPICAL POST WRAP DETAIL FIELD FORMED

REV. DATE: 2021.02.23

NOTE: INSTALLATION TO BE COMPLETED IN ACCORDANCE WITH MANUFACTURES SPECIFICATIONS. DO NOT SCALE DRAWINGS. MINIMUM SLOPE 1/4":12" AWAY FROM STRUCTURE. PLYWOOD SUBSTRATES TO BE MINIMUM 5/8" T&G (3/4" RECOMMENDED) PLYWOOD JOINTS TO BE BLOCKED FROM BELOW. AS A SUPPLIER OF MATERIALS ONLY, TUFF INDUSTRIES DOES NOT ASSUME RESPONSIBILITY FOR ERRORS IN DESIGN, ENGINEERING, QUANTITIES OR DIMENSIONS. THE ARCHITECT, CONTRACTORS OR OWNERS REPRESENTATIVE MUST VERIFY ALL DIMENSIONS, SIZES AND SUITABILITY OF DETAILS. THIS DRAWING IS THE PROPERTY OF TUFF INDUSTRIES INC. AND MAY NOT BE REPRODUCED WITHOUT WRITTEN CONSENT. ANY DIMENSIONS SHOWN ARE APPROXIMATE AND ARE SUBJECT TO FIELD CONFIRMATION BY OTHERS. CONTRACTORS NOTE: FOR PRODUCT INFORMATION VISIT: www.tufdek.com / www.econodek.com / www.tuff-shield.com